

WORK BENCHES

285 100



HEAVY DUTY WORK BENCH

Very robust all steel construction and epoxy coated finish. Includes one module with lockable shutter with one drawer, divided in 16 compartments, and one additional module with one shelf with large load capacity.

285 100* Heavy duty work bench with shutter
 Dimensions: 70" x 30" x 33.5"
 Gross weight: 380 lbs.

280 530



STEEL TOP WORK BENCHES WITH TWO DRAWERS

Steel top workbenches with two lockable drawers.

280 530* Steel top work bench with two drawers
 Dimensions: 70" x 30" x 33.5"
 Gross weight: 220 lbs.

280 430* Steel top work bench with two drawers
 Dimensions: 60" x 30" x 33.5"
 Gross weight: 200 lbs.

280 520



STEEL TOP WORK BENCHES WITH ONE DRAWER

Steel top workbenches with one lockable drawer.

280 520* Steel top work bench with one drawer
 Dimensions: 70" x 30" x 33.5"
 Gross weight: 200 lbs.

280 420* Steel top work bench with one drawer
 Dimensions: 60" x 30" x 33.5"
 Gross weight: 180 lbs.

280 320* Steel top work bench with one drawer
 Dimensions: 50" x 30" x 33.5"
 Weight: 160 lbs.

* Products delivered as kits.

WORK BENCHES

280 510



WOODEN TOP WORK BENCH

280 510* Wooden top work bench

Beech wood worktop with steel shelf and lateral supports. One or two optional drawers (part number 284 100) can be fixed to the wooden top.
 Dimensions: 70" x 30" x 33.5"
 Gross weight: 170 lbs.

280 500



STEEL TOP WORK BENCHES

Very robust all steel worktop with four "Z" shaped crossbeams, maximum load up to 2000 kg. Rectangular holes on the beams allow to fix drawers in different positions. Rectangular holes on worktop sides to fix tool board or cabinet brackets or to adjoin other benches.

Lateral supports can be fixed to the floor for maximum stability.

280 500* Steel top work bench

Dimensions: 70" x 30" x 33.5". Gross weight: 170 lbs.

280 400* Steel top work bench

Dimensions: 60" x 30" x 33.5". Gross weight: 150 lbs.

280 300* Steel top work bench

Dimensions: 50" x 30" x 33.5". Gross weight: 135 lbs.

280 200* Steel top work bench

Dimensions: 40" x 30" x 33.5". Gross weight: 120 lbs.

280 100* Steel top work bench

Dimensions: 30" x 30" x 33.5". Gross weight: 100 lbs.

ADDITIONAL SHELVES FOR WORK



To increase storage capacity under steel or wooden top workbenches. They include two transversal beams to fix the shelf to the side supports. Screws included.

289 309 Additional shelf for workbenches

Dimensions: 70" x 20". Gross weight: 45 lbs.

289 307 Additional shelf for workbenches

Dimensions: 60" x 20". Gross weight: 40 lbs.

289 305 Additional shelf for workbenches

Dimensions: 50" x 20". Gross weight: 35 lbs.

*Assembly required

281 500



TOOL CABINET

Tool cabinets with lockable shutter. Perforated tool panel for maximum capacity with tool hanging accessories included. Cabinets can be fixed to the wall, to a steel top work bench or to a heavy duty work bench using optional brackets.

281 500 Tool cabinet

Dimensions: 70" x 30" x 8".

Gross weight: 110 lbs. Includes a set of 9 tool brackets and a 45 hook set 289 101.

281 400 Tool cabinet

Dimensions: 60" x 30" x 8".

Gross weight: 100 lbs. Includes a set of 9 tool brackets and a 45 hook set 289 101.

281 300 Tool cabinet

Dimensions: 50" x 30" x 8".

Gross weight: 85 lbs. Includes a set of 7 tool brackets and a 30 hook set 289 100.

281 200 Tool cabinet

Dimensions: 40" x 30" x 8".

Gross weight: 70 lbs. Includes a set of 7 tool brackets and a 30 hook set 289 100.

289 105 Set of brackets for fixing a cabinet to a workbench

282 500



TOOL BOARD

Steel perforated panel for tool organisation. Can be fixed to the wall, to a steel top work bench or to a heavy duty work bench using optional brackets. Delivered in boxes containing two units.

282 500 Tool board

Dimensions: 70" x 30" x .75".

Gross weight: 40 lbs. Includes a set of 9 tool brackets and 45 hooks set 289 101.

282 400 Tool board

Dimensions: 60" x 30" x .75".

Gross weight: 35 lbs. Includes a set of 9 tool brackets and 45 hooks set 289 101.

282 300 Tool board

Dimensions: 50" x 30" x .75".

Gross weight: 30 lbs. Includes a set of 7 tool brackets and 30 hooks set 289 100.

282 200 Tool board

Dimensions: 40" x 30" x .75".

Gross weight: 25 lbs. Includes a set of 7 tool brackets and 30 hooks set 289 100.

282 100 Tool board

Dimensions: 30" x 30" x .75".

Gross weight: 13 lbs. Includes 1 multi-tool bracket and 30 hooks.

289 205 Set of brackets for fixing a board to a workbench

289 206 Set of brackets for fixing board 282 100 to a service trolley

*Assembly required

SERVICE TROLLEYS

283 900

283 100

283 202

283 201



TROLLEY WITH SHELVES

283 900* Cart with shelves
Trolley with three shelves, four castors (1.5") and 175 lbs. maximum load capacity. Dimensions: 25" x 15" x 30". Gross weight: 25 lbs.

STANDARD SERVICE TROLLEY

283 100* Standard service cart
Service cart with three shelves, two fixed wheels and two castors (3"). Middle shelf can be mounted in two different positions. Maximum load capacity: 440 lbs. Dimensions: 33" x 18 x 35". Gross weight: 45 lbs.

HD SERVICE TROLLEY

Very robust service cart with three shelves, two large wheels (6") and two castors (4"), one of them with brake for better stability and safety. Middle shelf can be mounted in two different positions, maximum load capacity: 440 lbs.

283 202* Heavy duty service cart with drawer
Includes drawer 284 201. Dimensions: 35" x 24" x 37". Gross weight: 65 lbs.

283 200* Heavy duty service cart
Dimensions: 35" x 24" x 37". Gross weight: 45 lbs.

SERVICE TROLLEY

283 201* Service cart
Service cart with three shelves, drawer and tool board, with one tool bracket with 30 hooks, for hanging tools. Very robust construction with two large wheels (6") and two castors (4") one of them with brake for better stability and safety. Maximum load capacity: 440 lbs. Gross weight: 75 lbs.

*Assembly required

ACCESSORIES

284 100



DRAWER FOR WORK BENCH

284 100 Drawer for service workbench

Drawer with lock and tray to be fitted directly under the steel or wood worktop of workbenches. Load capacity: 220 lbs. Dimensions: 26" x 6" x 20". Gross weight: 25 lbs.

284 201



DRAWER FOR SERVICE CART

284 201 Drawer for service trolleys

Drawer with telescopic guides to be fitted directly to the top shelf of service trolleys. Load capacity: 53 lbs. Dimensions: 18.5" x 16.25" x 2.25". Gross weight: 15 lbs.

282 501



PERFORATED PANELS FOR TOOL ORGANISATION

Perforated panel for fitting hooks and other tool hanging accessories. Strong steel frame with two wall brackets. Boards are delivered in packages containing two units.

282 501 Perforated panel 70"

Dimensions 70" x 30" x .75". Gross weight: 22 lbs.

282 401 Perforated panel 60"

Dimensions 60" x 30" x .75". Gross weight: 20 lbs.

282 301 Perforated panel 50"

Dimensions 50" x 30" x .75". Gross weight: 16.5 lbs.

282 201 Perforated panel 40"

Dimensions 40" x 30" x .75". Gross weight: 14 lbs.

282 101 Perforated panel 30"

Dimensions 30" x 30" x .75". Gross weight: 11 lbs.

STANDARD ACCESSORY SETS FOR TOOL BOARDS AND CABINETS

Set of accessories for an optimum organization of tools on boards and in cabinets. Each set includes the hooks and tool brackets mentioned in the following table:

PART N°	289 108	289 107	289 106	728 901	728 900	728 903	728 902	728 907	728 905	728 904	728 906
289 101	1	1	1	2	1	1	1	1	1	1	1
289 100	1	1	-	1	1	1	1	1	1	1	1
289 109	-	1	1	-	-	-	-	1	-	-	-

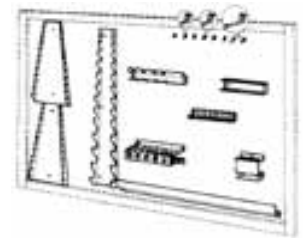

TOOL SUPPORTS, BRACKETS AND RAIL KITS

PART N°	DESCRIPTION	DIMENSIONS
728 900	Bracket for 13 box spanners	4 x 25 x 2 inches
728 901	Bracket for 13 spanners	6.25 x 14.25 x 1.75 inches
728 902	Bracket for 20 drive sockets	26.25 x 1.75 x 2 inches
728 903	Bracket for 12 allen keys	6.5 x 1.25 x 1 inches
728 904	Bracket for 11 sets of pliers-screwdrivers - files	8 x 1.25 x 1 inches
728 905	Bracket for 6 screwdrivers	9.25 x 1.5 x 1.25 inches
728 906	Bracket for 18 bits - punches - chisels	4 x 3.25 x 1.75 inches
728 907	Universal "multi-tool" bracket	9.25 x 2.75 x 3.5 inches
728 909	Small "multi-tool" bracket	3 x 2.75 x 3.5 inches
728 910	Set of drill brackets	2.5 x 1.75 x 4 inches
728 924	Tray for panel - cabinet	32 x 1.5 x 4 inches
289 400	Paper roll supports	
728 911	Nut and bolt set for bench assembly	
289 312	60" rail kit. Fits 60" bench	
289 314	70" rail kit. Fits 70" bench	

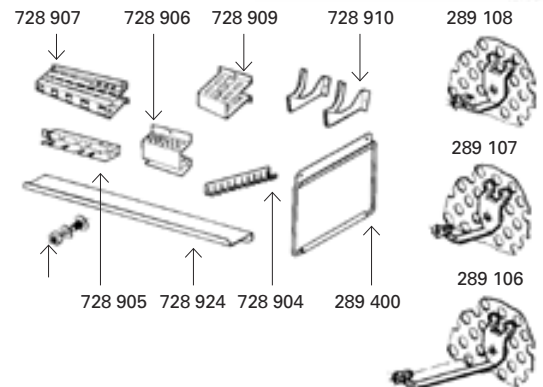

HOOKS FOR PERFORATED PANELS

289 108 short hooks set (15 units)

Length: .75". Screws included.

289 107 long hooks set (15 units)

Length: 1.25". Screws included.

289 106 extra long hooks set (15 units)

Length: 3". Screws included.

289 110 short hooks set (5 units)

Length: .75". Screws included.

289 111 long hooks set (5 units)

Length: 1.25". Screws included.

289 112 extra long hooks set (5 units)

Length: 3". Screws included.

*Assembly required